

# **Minuteman<sup>®</sup>**

## **Allergy Vacuum**



**Optional electric powerhead**

**Standard 6-piece tool kit**

**Optional air-driven turbo brush**

*Capture common allergens like pollen, dust, mold, animal dander, and dust mites with the Allergy Vacuum from Minuteman.*

# The most effective vacuum for the removal of allergens

## An Easy and Affordable Solution for Allergy Relief

Common allergens, such as pollen, mold, animal dander, and dust mites collect in carpeting, draperies, bedding and furniture. Allergy sufferers can find relief using Minuteman's Allergy Vacuum to combat these allergens.

Unlike conventional household vacuums which exhaust unseen contaminants back into the air and may actually cause an allergic reaction, the Allergy Vacuum traps harmful allergens with progressively finer stages of filtration. Its four-stage filtration system includes: a disposable paper bag, a washable embossed polyester filter bag, a disposable impact filter and a H.E.P.A.-type (High Efficiency Particulate Air) filter that is 99% efficient at 0.3 microns.

As an added precaution, if the H.E.P.A.-type filter is removed, the vacuum will not operate. This patented safety interlock system assures user safety and prevents allergens from being redistributed back into the air.

The Allergy Vacuum comes complete with tool kit and caddy.

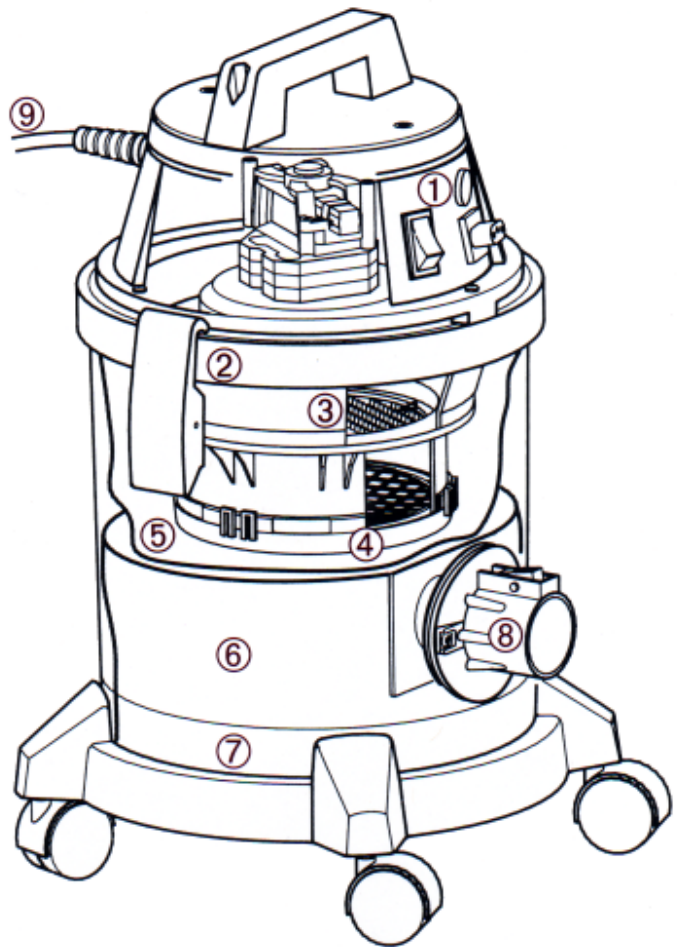

- 1 Full Bag indicator light alerts user when vacuum needs to be emptied
- 2 Patented safety interlock system prevents vacuum from operating unless high efficiency filter is aligned and in place
- 3 H.E.P.A.- type filter is 99% efficient at 0.3 microns
- 4 Pink impaction filter is 95% efficient at 0.3 microns
- 5 Embossed polyester filter bag is 99% efficient at 1.5 microns
- 6 Disposable paper bag is 99% efficient at 5 microns
- 7 4- gallon polyethylene tank is noncorrosive and dent-proof
- 8 Patented self sealing intake
- 9 Convenient 40 foot cord

### FEATURES

## SPECIFICATIONS

<b>Tank Capacity</b>	4 gallons (15 ltrs)
<b>Power</b>	1.25 hp (.93 kw)
<b>Dry Capacity</b>	.21 cu. ft. (.006 m <sup>3</sup> )
<b>CFM</b>	95 (2.69 m <sup>3</sup> )
<b>Static Lift</b>	85 in. (2160 mm)
<b>DbA Rating</b>	68
<b>Casters</b>	4 - 2 in. (5 cm)
<b>Cord</b>	40ft. (12 m)
<b>Weight</b>	16 lbs. (7 kg)

\*Specifications subject to change without notice.

# Minuteman®

World Headquarters  
Minuteman International, Inc.  
111 South Rohlwing Road  
Addison, IL 60101-4244  
Telephone: (630) 627-6900  
Fax (630) 627-1130

Minuteman Canada, Inc.  
2210 Drew Road  
Mississauga, Ontario Canada L5S 1B1  
Telephone: (905) 673-3222  
Fax: (905) 673-5161

