

# Minuteman Monthly

**Inside this issue:**

- New E-Series to be introduced **1**
- V10 Pro Spotlited **2**
- International presence **2**
- Customer Service and More **3**



- Interested in becoming a Minuteman Dealer? Inquire today to learn all the benefits and features of choosing the Minuteman line of equipment.

Contact:  
Jack Hill  
VP Sales  
630-570-2372

## New E-Series to be introduced in 2010

With 2009 behind us, Minuteman is excited to introduce several new machines to it's already stellar product line. The E- Series which currently boasts several Rider Scrubbers and walk behind scrubbers will be welcoming two new units which will come in several models. Beginning in May of 2010 Minuteman will introduce the ERide 28Plus and 32Plus to it's offering. These units will come standard with a 32 gallon solution tank, and 38 gallon recovery tank, curved break-away rear squeegee assembly, interchangeable 28" or 32", cylindrical or disc scrub decks, and a 1HP, 3-Stage tangential bypass vacuum motor. "This is a very exciting time being able to take an existing product (SCV 28/32) and re-work it from head to toe with the goal of engineering a top notch of product which we believe we have accomplished" Said Jesse Mondigo, Director of Engineering. The ERide

28/32Plus units have also been engineered to accomplish longer run time, best in class maneuverability, increased quality and safety, along with a very competitive price.

*For more information on the new Minuteman product offering please contact Minuteman Customer Service at:*

**(800) 323-9420**

Or

**customerservice@minutemanintl.com**

## EZ Parts Login

EZ Parts can be accessed through the [www.minutemanintl.com](http://www.minutemanintl.com)—Just Click "Parts Catalog"

Minuteman has made this impressive program available directly through their homepage in an effort to give our dealers in the field direct access.

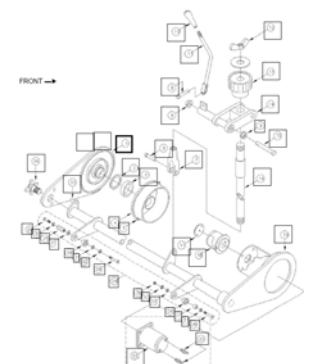
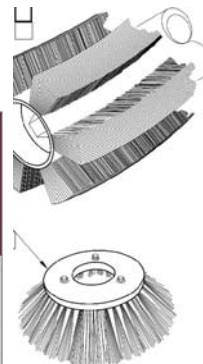

## Product Spotlight: V10 Pro - Back Pack Vacuum



The Minuteman V10 Pro is the newest member added to the Minuteman product line. The V10Pro back pack vacuum is specifically designed with ergonomics for the operators complete comfort ability and safety. This unit comes with a three stage filtration and an optional 99.97% efficient HEPA filter. The power switch has been integrated directly into the waist harness for ease of operation. The elliptical shape of the V10 Pro reduces the units foot print and allows for greater maneuverability. The clear dome allows the operator to view capacity inside debris bag. The V10Pro uses impedance reduced air-flow and blended fiber technology for maximum

strength and durability of this unit.

For more information on the V10 Pro, visit us on the web at:

[www.minutemanintl.com](http://www.minutemanintl.com)



Minuteman has targeted a wide array of Brooms & Brush's based on specific machine sales to give our dealers a price they cant beat. We have discounted many of these brooms and brush's by more than 50% to let our dealer network know we mean business. A 17" Strata Grit brush is now only \$45.00 during this promotion. The entire promotion and brush guide can be found on the Minuteman dealer web-site.



Sweeping Brush Application Guide

	Unreinforced Concrete	High Density on Mason	Reinforced Concrete	Brick	Asphalt	Gravel	Grass	Concrete	Asphalt	Gravel	Grass
Pine Deet											
Gravel & Compacted Dirt											
Compacted Gravel											
Gravel											
High Density on Mason											
Reinforced Concrete											
Brick											
Asphalt											
Gravel											
Grass											
Concrete											
Asphalt											
Gravel											
Grass											
Concrete											
Asphalt											
Gravel											
Grass											

Visit the Minuteman dealer website to view this list today!

## Ventas Internacionales ?

Through economic uncertainties Minuteman has continued to grow it's International presence. Our International dealer base stretches world wide including Mexico/Columbia, Indian Sub continental, Persian Gulf, and across the oceans via the United States Navy. "We're very pleased knowing that Minuteman product is currently in use keeping commercial locations all over the world clean" Said Chris Failla, Minuteman international sales specialist. "This is consistent with our new Dealer sign up campaign"



Minutemanintl.com

Headquarters:  
Minuteman International  
14N845 US Rt. 20  
Pingree Grove, IL 60140-8893 USA  
Toll Free: 800-323-9420  
Phone: 847-264-5400  
A Member of the Hako Group

## Customer Service: Price Pages, and More

Minuteman Customer service will have the 2010 product offering (Price Pages) available this week. "It is very important that we ask our dealers to supply us with updated contact information so we can update our system, packaging slips, invoices, etc." said Dan Spapperi, Minuteman Customer Care Manager. "It's critical that we stay in touch with our dealer network, and it all starts with keeping us in the loop on critical information." Please provide updated information to us if applicable.

### **Sales Tax-Resale Certificates 2010:**

It is imperative that our U.S. dealers fill out the form located on the Minuteman dealer website. Unless Minuteman receives a completed Tax-resale form by the end of February all sales will be treated as taxable, and a sales tax will apply to current PO's.



## Technical Service Staff



***"I enjoy using my field knowledge to help diagnose and assist our dealer network in getting their machines back in action."***

**Greg Fisher,  
Technical  
Service Rep**

In our ongoing effort to increase customer satisfaction, Minuteman has added an additional Technical Service Representative to its ever-growing staff. Greg Fisher transferred internally from Minuteman/PowerBoss's Villa Park, IL location to the Minuteman HQ located in Pingree Grove, IL in late September, and with him he brings six years of technical knowledge on servicing and maintaining these robust machines. "I enjoy using my field knowledge to help diagnose and assist our dealer network in getting their machines back in action." said Greg Fisher, Minuteman Tech Service. Greg also works hand in hand with Terry Hartsell both seasoned technical support staff team members. Between the two representatives they often log upwards of 1400 phone calls a month, or roughly 350 a week in assisting Minuteman related technical questions. Keep up the good work!

### **Minuteman Tech Support**

**M-F: Hours 7a.m.—5p.m. CST**

630-627-6900

customerservice@minutemanintl.com

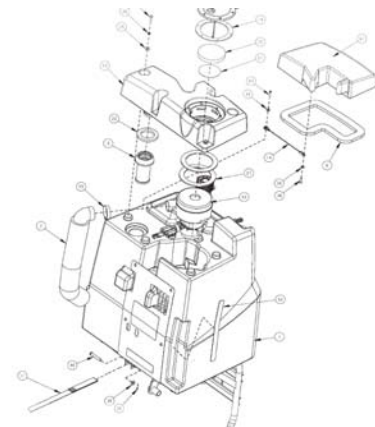

Dealer Information

Dealers.PowerBoss.com



**Minuteman International**

