

Parts and Instruction Manual 390 55 Gallon Vacuum



PREFACE

Thank you for your purchase of the new industry standard for vacuums. Minuteman International takes great pride in offering the most dependable, reliable and best value in industrial floor cleaning equipment. We set the standard.

Our Customer Service Department would like to hear from you. If you see any errors, omissions or something that needs clarification in this Parts Catalog please let us know. We are working hard towards continually improving our processes to bring you the best you deserve.

Thank you!

The Minuteman International Team

Model: C39055-03

Table of Contents

- Important Safety Instructions..... 4**
- Inspection..... 5**
- Electrical..... 5**
- Grounding Instructions..... 5**
- User Maintenance Instructions 6**
- Cloth Bag & Hose Assembly 6**
- Cord Storage..... 6**
- Exploded Views 8**
 - Lid Assembly..... 8
 - Tank Assembly..... 10
 - Dolly Assembly11

FOR COMMERCIAL USE ONLY

IMPORTANT SAFETY INSTRUCTIONS

When using an electrical appliance, basic precautions should always be followed, including the following:

READ ALL INSTRUCTIONS BEFORE USING

WARNING - To reduce the risk of fire, electric shock, or injury:

- Do not leave appliance when plugged in. Unplug from outlet when not in use and before servicing.
- To avoid electrical shock, do not expose to rain, store indoors.

WARNING:

To reduce the risk of electrical shock - Do not use on wet surfaces. Do not expose to rain. Store indoors.

- Do not allow to be used as a toy. Close attention is necessary when used by or near children.
- Use only as described in this manual. Use only manufacturer's recommended attachments.
- Do not use with damaged cord or plug. If appliance is not working as it should, has been dropped, damaged, left outdoors, or dropped into water, return it to a service center.
- Do not pull or carry by cord, use cord as a handle, close a door on cord, or pull cord around sharp edges or corners. Do not run appliance over cord. Keep cord away from heated surfaces.
- Do not unplug by pulling on cord. To unplug, grasp the plug, not the cord.
- Do not handle plug or appliance with wet hands.
- Do not put any object into openings. Do not use with any opening blocked; keep free of dust, lint, hair, and anything that may reduce air flow.
- Keep hair, loose clothing, fingers, and all parts of body away from openings and moving parts.
- Do not pick up anything that is burning or smoking, such as cigarettes, matches, or hot ashes.
- Do not use without dustbag and/or filters in place.
- Turn off all controls before unplugging.
- Use extra care when cleaning on stairs.
- Do not use to pick up flammable or combustible liquids such as gasoline or use in areas where they may be present.
- Connect to a properly grounded outlet only. See grounding instructions.

SAVE THESE INSTRUCTIONS

Inspection

Carefully unpack and inspect your machine for shipping damage. Each unit is tested and thoroughly inspected before shipment, and any damage is the responsibility of the delivery carrier who should be notified immediately.

Electrical - 115 Volt

This machine is designed to operate on a standard 15 amp, 115 volt, 60 hz, AC circuit. Voltages below 105 volts AC or above 125 volts AC could cause serious damage to the motor.

Grounding Instructions

This appliance must be grounded. If it should malfunction or breakdown, grounding provides a path of least resistance for electric current to reduce the risk of electric shock. This appliance is equipped with a cord having an equipment-grounding conductor and grounding plug. The plug must be plugged into an appropriate outlet that is properly installed and grounded in accordance with all local codes and ordinances.

DANGER

Improper connection of the equipment-grounding conductor can result in a risk of electric shock. Check with a qualified electrician or service person if you are in doubt as to whether the outlet is properly grounded. Do not modify the plug provided with the appliance — if it will not fit the outlet, have a proper outlet installed by a qualified electrician.

This machine is for use on a nominal 120 volt circuit and has a grounding plug that looks like the plug illustrated in Sketch A. Make sure that the machine is connected to an outlet having the same configuration as the plug. No adapter should be used with this appliance.

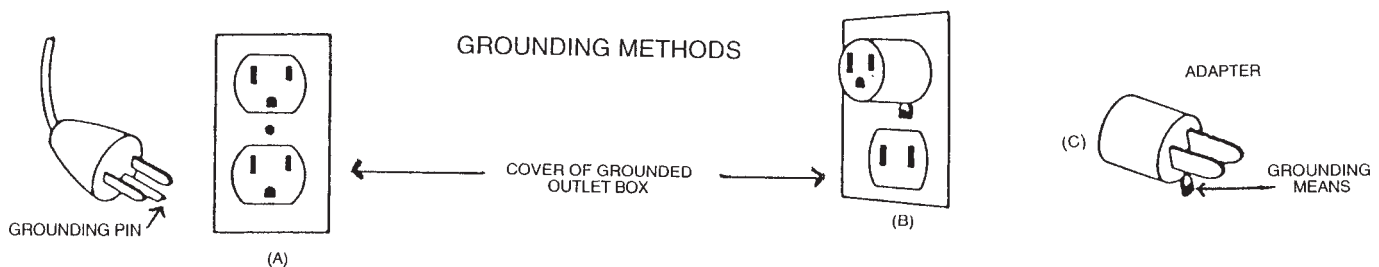

WARNING

This vacuum may contain potentially hazardous dust depending on its application. Special handling of contaminated disposal bags and filters is recommended. Disposal must be in compliance with local EPA regulations

User Maintenance Instructions

All service and repair should be performed by qualified vacuum service representative or electrician. No user serviceable components are employed in the electrical vacuum lid head assembly. No lubrication of the motor is required.

Cloth Bag & Hose Assembly





Cloth bag and hose assembly are user maintenance items and can be replaced when worn out. For optimum performance, empty and clean filter bag regularly. A clogged and dirty bag restricts the flow of air and results in reduced vacuum. The hose assembly can be maintained by wiping off with a dampened cloth of mild liquid soap and water, then allowed to dry.

Cord Storage

While not in use storage can be accomplished by winding cord around motor lid assembly. Cord should be completely unwound from lid assembly during operation.

- Do not use with damaged cord or plug. If appliance is not working as it should, has been dropped, damaged, left outdoors, or dropped into water, return to service center.
- Do not pull or carry by cord, use cord as handle, close a door on cord, or pull cord around sharp edges or corners. Do not run appliance over cord. Keep cord away from heated surfaces.
- Do not unplug by pulling cord. To unplug, grasp the plug, not the cord.
- Do not handle plug or appliance with wet hands.
- Always unplug the machine when removing the motor head off the tank.
This equipment should be stored indoors and not exposed to rain.

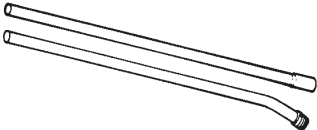
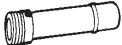
Always unplug the machine when removing the motor head off the tank. This equipment should be stored indoors and not exposed to rain.

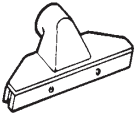
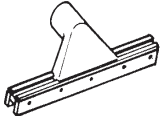
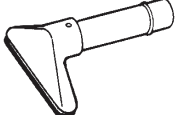
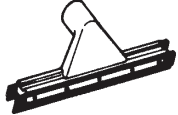
A		800024 800022 800023 800175MCH 800176MCH 800025	3" Rd Dust Brush Complete 5" Rd Dust Brush Complete Bristle Insert 5" Dust Brush HSG 5" Dust Brush HSG 3" Bristle Insert 3"
B		800034	24" Crev Tool Aluminum Comp
C		800015	Wand Asy 1-1/2, Complete
D		800017 800064 800019	Set Tube, High-up 10' 5' Tube Lower Section 5' Section Upper
E		800116	Swivel, Hose End Exp, Comp
F		800317	Hose Asy 1-1/2 x 10'
G		800032 711006 800033 800193POL	6" Curved Pipe Tool, Comp Set Screw Bristle Insert Curved 6" 6" Curved Pipe Tool
H		800070 710356 710357 800187PTD 800217 800218	12" Gulper Tool, Comp SCR-MC 10-32 x .62 SCR-MC 10-32 x .75 Gulper Nozzle Fibre Shoe Rear Fibre Shoe Front
I		800108 710530 800003MCH 800178PTD	14" Fibre Tool Complete Screw 8/32 x 1/2 Brass Fibre Shod Tool Casting
J		800038 800029	6" Tool Squeegee, Complete Bristle Insert Replacement
K		800109 710330 800121 800178PTD 800239 800240	14" Squeegee, Comp SCR-SC 8-32 x .62 14" Retaining Strip Casting, Tool MCH Blade Squeegee Wide Blade Squeegee Narrow

**Exploded Views
Lid Assembly**

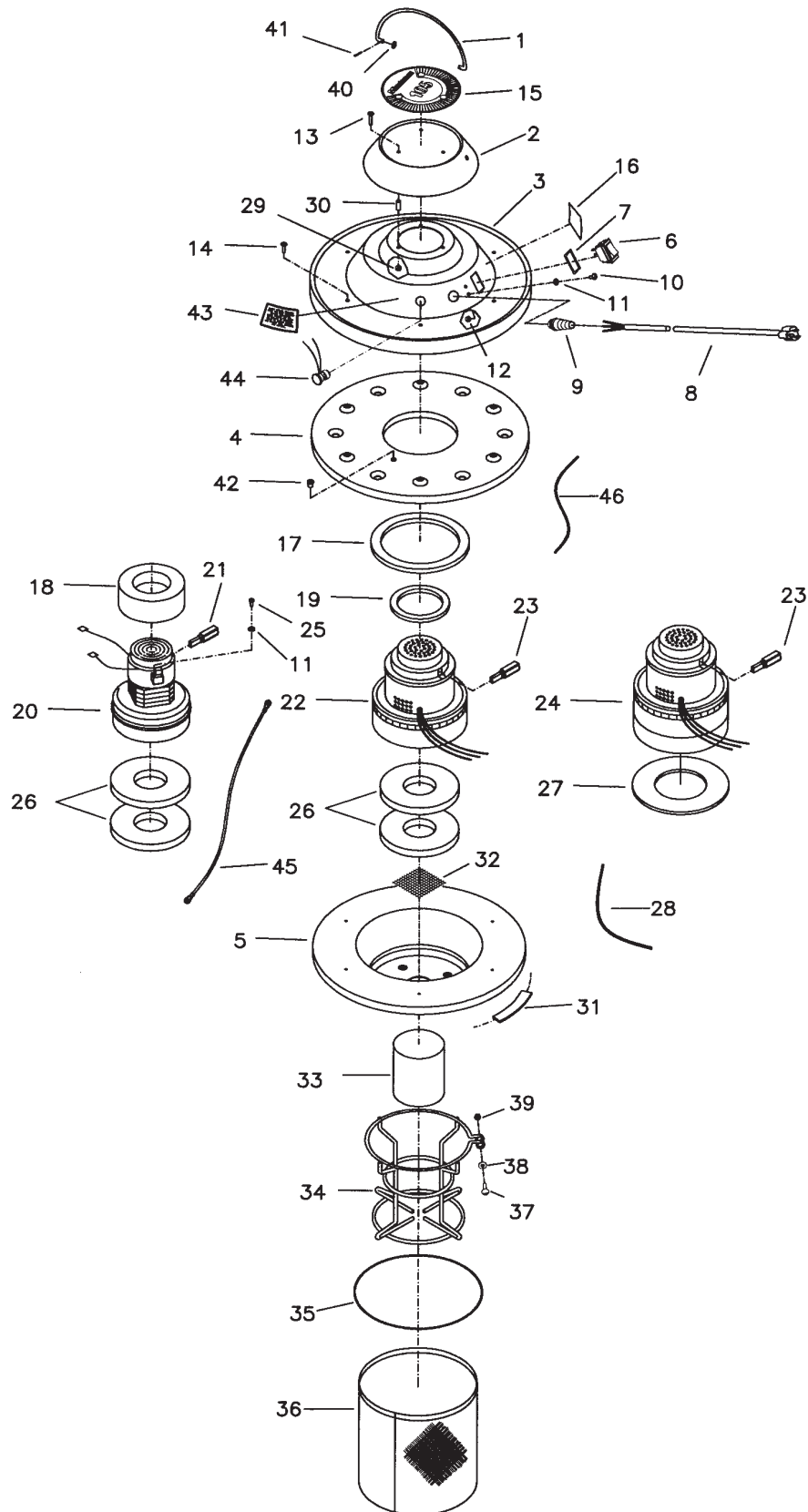

ITEM	PART NO.	QTY	DESCRIPTION
1	760899	1	Handle Bail
2	760898PLT	1	Cap, Motor
3	760897PLT	1	Cover, Motor
4	760896	1	Shroud, Motor
5	760895PLT	1	Pan, Motor
6	809755	1	Switch, Rocker
7	450088	1	Spacer, Switch
8	381020	1	Gray Cord Ste 16-3 50'
9	833237	1	Strain Relief
10	710355	2	SCR-MC 10-32 x .50 STPL
11	711553	2	WSR-Internal Lock #10
12	711310	2	Nut-Hex 10-32 x .50 STPL
13	712823	3	SCR-THMS 10-24 x 1.00 STPL
14	711126	6	SCR-ST-B 10 x .75 STPL
15	715105	1	Decal, P/V 105
16	715086	1	Decal, Warning
17	831478	1	Gasket, Neop 6 x 7.5 x .37
19	831484	1	Gasket, 3.5 x 4.5 x .31
22	255039	1	Vac Motor, Bypass 115V-105
23	255008	2	Brush, Carbon-105
26	828995	2	Gasket, Neop 2.5 x 6 x .62
28	760213	1	Venturi Tube
29	712908	3	Nut-Flanged Wizz 10-24
30	831652	3	Spacer
31	290030	1	Lid Gasket
32	807051	1	Screen Filter SS 85/105
33	830987	1	Float
34	833454	1	Float Cage
35	760260	1	Spring, Bag Retainer
36	760901	1	Lint Filter
37	710190	1	SCR-THMS 1/4-20 X 2 SS
38	711506	1	WSR-Flat 5/16 ST PL
39	712667	1	Nut-Hex 1/4-20 SS Nyloc
40	711505	2	WSR-Flat 1/4
41	711803	1	Cotter Pin
42	760904	1	Snub Bushing
43	715069	1	Decal, Check Filters
44	740088	1	Vac Light
45	740116	1	Ground Wire
46	760212	1	Vac Sensor Tube

Tank Assembly

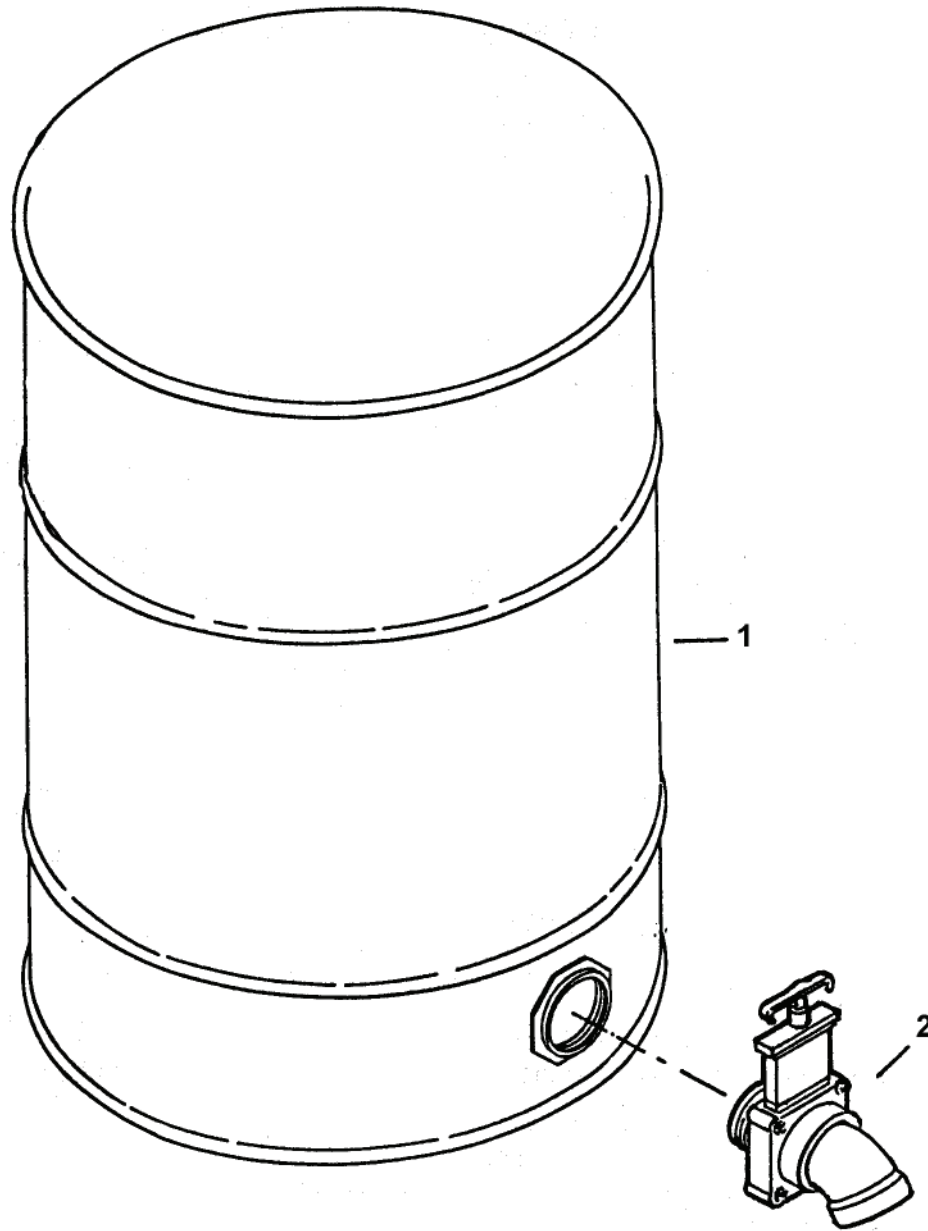

ITEM	PART NO.	QTY	DESCRIPTION
1	900015PTD	1	Tank 55 Gal. PTD No Handles
2	900047	1	Dump Valve

Dolly Assembly

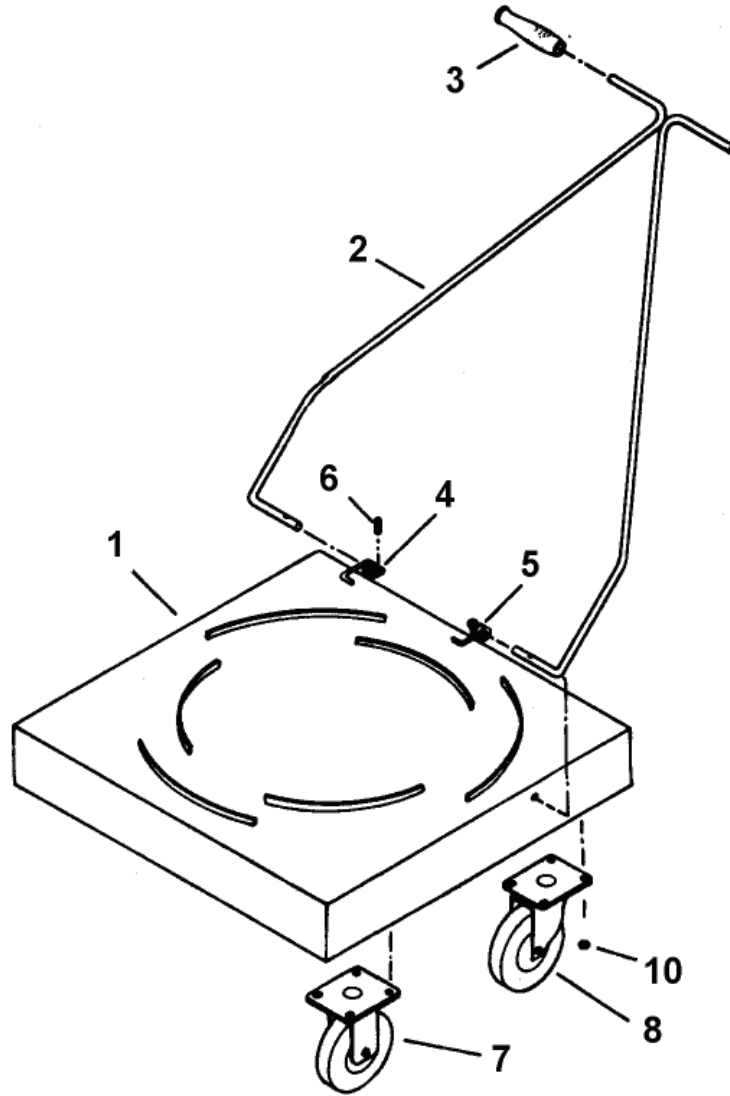

ITEM	PART NO.	QTY	DESCRIPTION
1	750045	1	Weldment Dolly 30/55
2	900051	1	Weldment Handle
3	900052	2	Grip, Handle
4	900080	1	Spring, Torsion RH
5	900081	1	Spring LH
6	711642	2	Rollpin
7	761050	2	Caster, Rigid 5"
8	761049	2	Caster, Swivel 5"
10	711379	16	Nut-Hex 5/16-18 ST PL

“Excellence Meets Clean”

**Minuteman is a Full Line Manufacturer of Sweepers and Scrubbers,
for Industrial Facilities.**