

User Manual

X17 ECO CFS Carpet Extractor
115V/230V with High Pressure



Technical Specifications

This manual is furnished with each new **Minuteman X17 ECO CFS**. This provides the necessary operating and preventive maintenance instructions. Operators must read and understand this manual before operating or servicing this machine.

This machine was designed to give you excellent performance and efficiency. For best results and minimal cost, please follow the general guidelines below:

- Operate the machine with reasonable care.
- Follow the manufacturer's suggested maintenance instructions as provided in this booklet.
- Use original Minuteman supplied parts.

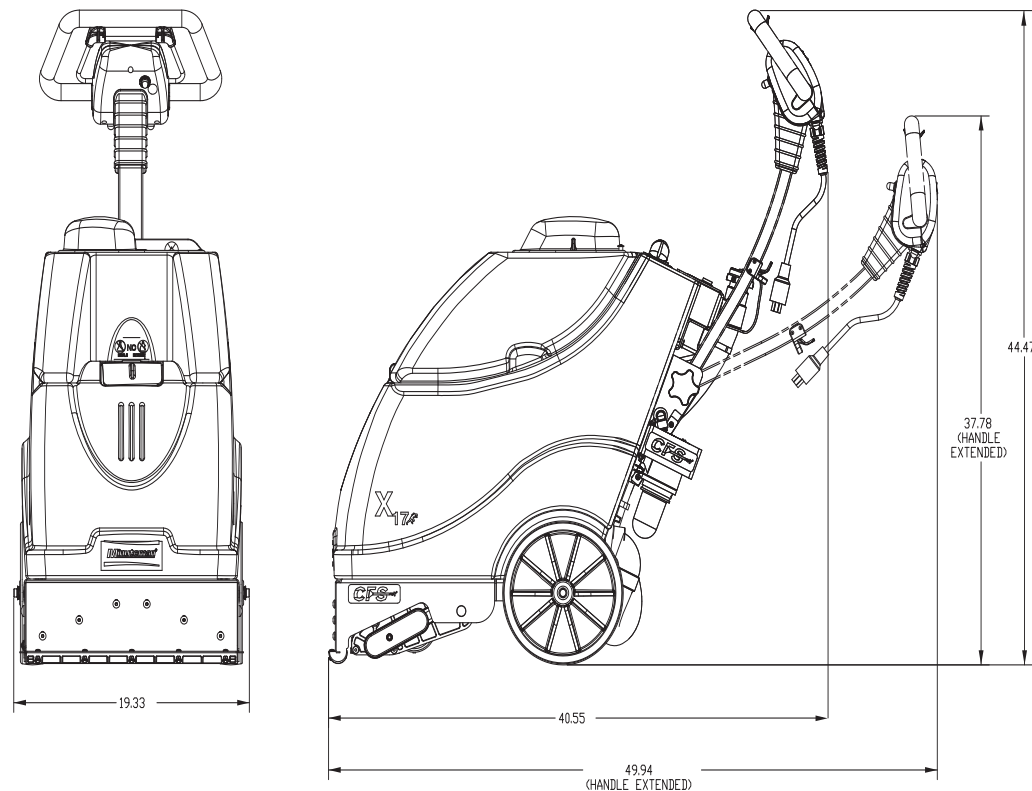

Model: X17 ECO CFS (Chemical Free Solution) with HP (High Pressure)

<u>Model No.</u>	<u>X17115Z / X17115HPZ</u>	<u>X17230Z/X17230HPZ</u>
Current Max.	12.5 Amps	7 Amps
Voltage	115V	230V
Vacuum motor power	1250W	1250W
Brush motor power	100W	100W
Pump motor power	50PSI / 100PSI (HP)	50PSI / 100PSI (HP)
Working width	17 in.; 43 cm	17 in., 43cm
Gross Weight	116 lb.; 52.6 kg	116 lb.; 52.6 kg
Solution tank	10 Gallons; 37.8 LITERS	10 Gallon; 37.8 LITERS
Recovery tank	7 Gallons; 26.5 LITERS	7 Gallon; 26.5 LITERS
Power Cord Length	50 ft.; 15.24m	50 ft.; 15.24m
Suction (sealed)	100in. of water	100in. of water
*Vibration	< 8.2 ft/s ² ;	<2,5 m/s ²

Noise emission

The sound pressure level measured under maximum conditions of use (LwA) according to DIN EN 60335-2-68	83 dB (A)
The sound pressure level measured (at the ear of the driver) under normal conditions of use (LpA) according to DIN EN 60335-2-68	72 dB (A)
Measurement inaccuracy (KpA)	1,8 dB (A)

*The frequency weighted acceleration measured according to DIN EN ISO 5349 which have an effect upon the upper limbs (hand-arm-system) amounts under normal working conditions.

Table of Contents

Technical Specifications	2
Table Of Contents	4
Safety Instructions	6
Unpacking Instructions.....	7
Assembly.....	8
Handle Assembly Instructions.....	8
Machine Overview	13
X17 CFS Front.....	13
Vacuum Connection.....	13
X17 CFS Back & Bottom.....	14
Handle/ Control Panel.....	15
Circuit Breakers.....	16
Solution Tank In-line Filter	17
Vacuum Intake Filter	17
Solution Tank Drain Hose.....	18
Solution Level Indicator.....	18
Brush Removal.....	19
Brush Pressure Gauge	20
Brush Pressure Adjustment Knob.....	20
Removable Recovery Tank.....	21
High Pressure Spray System (HP).....	21
Handle Adjustment.....	22
Cord Relief	22
Accessories	23

Maintenance..... 24

Operating Instructions..... 27

Chemical Free Solution Unit..... 29

Troubleshooting CFS Unit.....30

Troubleshooting 31

Warranty 34

Safety Instructions

FOR COMMERCIAL USE ONLY IMPORTANT SAFETY INSTRUCTIONS

READ ALL INSTRUCTIONS BEFORE OPERATING EQUIPMENT

When using an electrical appliance, basic precautions should always be followed, including the following:

WARNING - To reduce the risk of fire, electric shock, or injury:

- Do not leave appliance when plugged in. Unplug from outlet when not in use and before servicing.

WARNING - To reduce the risk of electrical shock, do not expose to rain. Store indoors.

- Never allow children or untrained adults to operate this equipment.
- Keep the area of operation clear of all persons, particularly small children, and pets. Keep bystanders at least 25 feet away from the area of operation.
- Use only as described in this manual. Use only manufacturer's recommended attachments.
- Do not use with damaged cord or plug. If appliance is not working as it should, has been dropped, damaged, left outdoors, or dropped into water, return it to a service center.
- Do not pull or carry by cord, use cord as a handle, close a door on cord, or pull cord around sharp edges or corners.
- Do not run appliance over cord.
- Keep cord away from heated surfaces.
- Do not unplug by pulling on cord. To unplug, grasp the plug, not the cord.
- Do not handle plug or appliance with wet hands.
- Do not put any object into openings. Do not use with any opening blocked; keep free of dust, lint, hair, and anything that may reduce air flow.
- Keep hair, loose clothing, fingers, and all parts of body away from openings and moving parts.
- Do not pick up anything that is burning or smoking, such as cigarettes, matches, or hot ashes.
- Turn off all controls before unplugging.
- Use extra care when cleaning on stairs.
- Do not use to pick up flammable or combustible liquids such as gasoline or use in areas where they may be present.
- Connect to a properly grounded outlet only. See grounding instructions.
- If foam/liquid comes out of exhaust openings turn switch off immediately.
- Use only chemicals recommended by dealer/manufacturer.
- These machines must be used only with the power supply cord provided from the manufacturer:
 - X17115Z / X17115HPZ: Power Cord #748613
 - X17230Z / X17230HPZ: Power Cord #748613CE

SAVE THESE INSTRUCTIONS

INSPECTION

Carefully unpack and inspect your machine for shipping damage. Each unit is tested and thoroughly inspected before shipment, and any damage is the responsibility of the delivery carrier who should be notified immediately.

ELECTRICAL

Model Numbers X17115Z / X17115HPZ are designed to operate on a standard 15 amp, 115 volt, 60 hz, AC circuit. Voltages below 105 volts AC or above 125 volts AC could cause serious damage to the motor. Model Numbers X17230Z / X17230HPZ are designed to operate on a standard 10 amp, 230 volt, 50 hz, AC circuit. Voltages below 210 volts AC or above 250 volts AC could cause serious damage to the motor.

WARNING

Electric motors and components can cause an explosion when operated near explosive materials or vapors. Do not operate this machine near flammable materials such as solvents, thinners, fuels, grain dust, etc. See Warning Decal, #715061, page 23.

GROUNDING INSTRUCTIONS

This floor-finishing machine shall be grounded while in use to protect the operator from electric shock. The machine is provided with a three-conductor cord and a three-contact grounding type attachment plug to fit the proper grounding type receptacle. The green (or green and yellow) conductor in the cord is the grounding wire. Never connect this wire to other than the grounding pin of the attachment plug.

DANGER

Improper connection of the equipment-grounding conductor can result in a risk of electric shock. Check with a qualified electrician or service person if you are in doubt as to whether the outlet is properly grounded. Do not modify the plug provided with the appliance — if it will not fit the outlet, have a proper outlet installed by a qualified electrician.

Model Numbers X17115Z / X17115HPZ are for use on a nominal 115-volt circuit and has a grounding plug that looks like the plug illustrated in Figure 1.

Model Numbers X17230Z / X17230HPZ are for use on a nominal 230-volt circuit and has a grounding plug that looks like the plug illustrated in Figure 2.

Make sure that the appliance is connected to an outlet having the same configuration as the plug. No adapter should be used with this appliance.

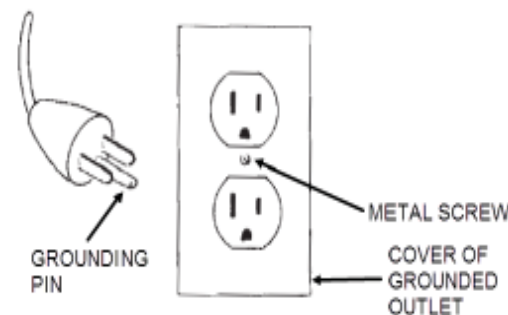

Figure 1

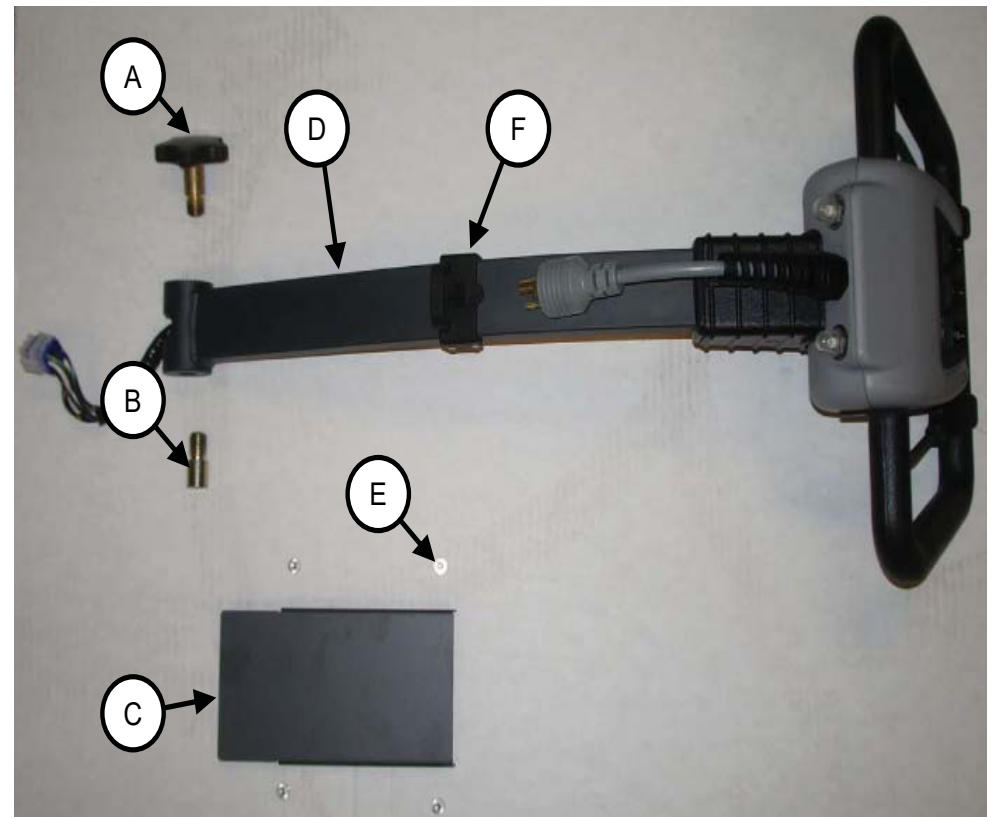

Figure 2

Handle Assembly Instructions

The X17 CFS **Handle Assembly (D)** is not assembled on the machine when shipped. Follow the instruction on the next pages to connect the handle assembly to the machine.

- A HANDLE ADJUSTMENT KNOB**
- B SHOULDER BOLT**
- C COVER**
- D HANDLE ASSEMBLY**
- E SCREW**
- F CORD RELIEF**



Handle Assembly Instructions

1. Unpack machine.
2. Using phillips head screwdriver, **LOOSEN** all four screws holding on the back cover plate. **DO NOT REMOVE SCREWS.**

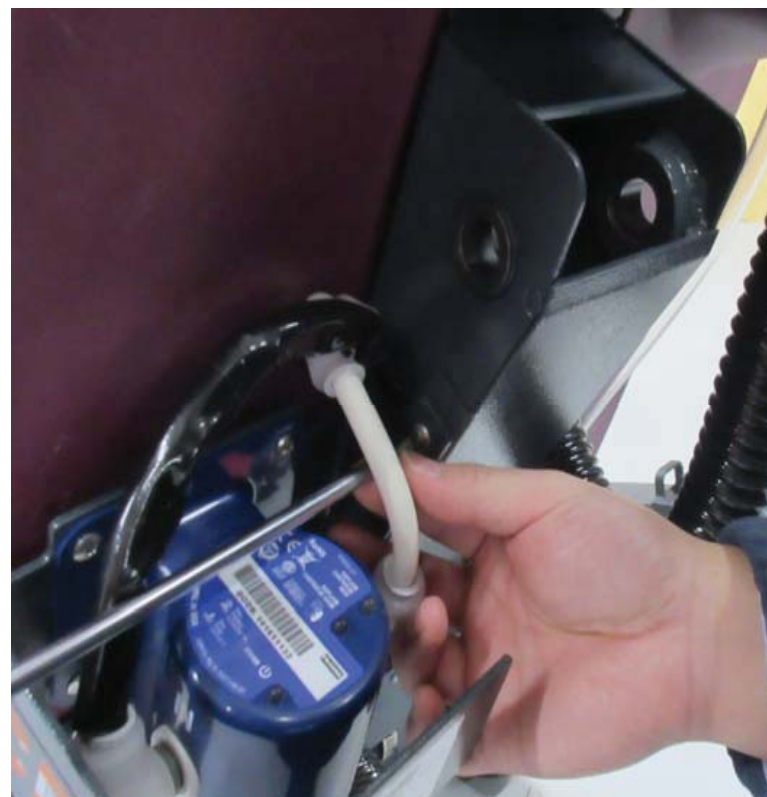

3. Push the plate up and pull it gently back to remove. Set aside.

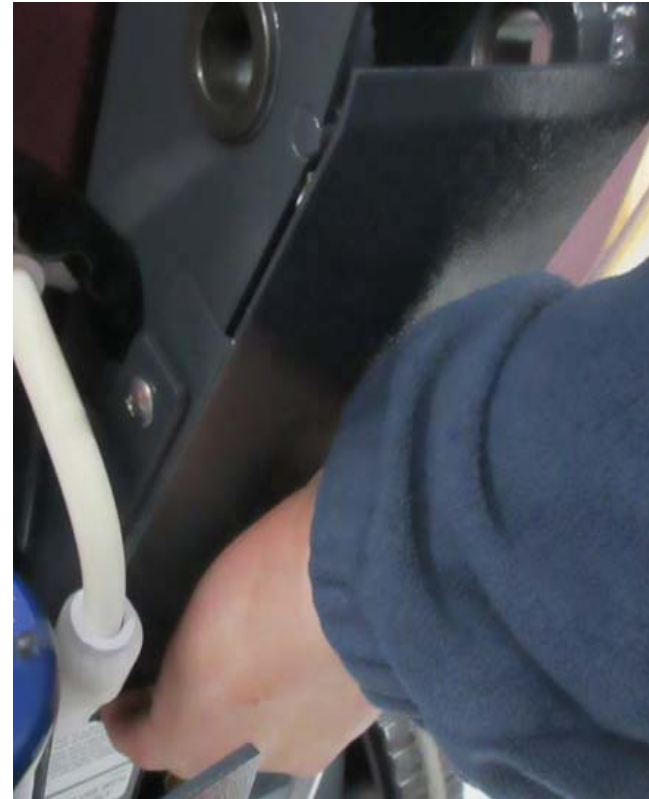

3. Push the plate up and pull it gently back to remove. Set aside.

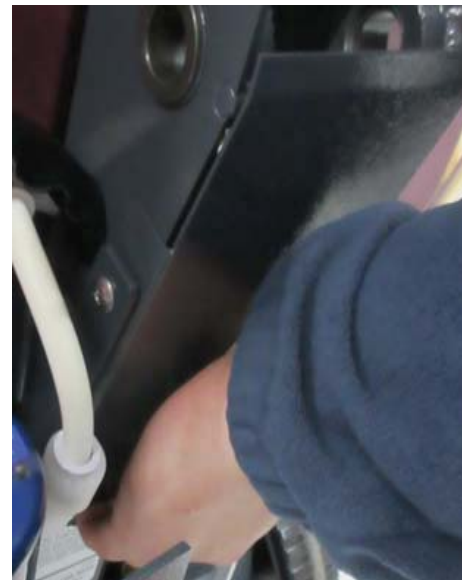

Assembly

5. Align the teeth on the bushing and handle assembly before tightening the adjustment knob.
6. Turn the adjustment knob clockwise to tighten.



7. Attach the wire harness to the machine, making sure that the patterns are lined up correctly.
8. Slide the cover back onto the four screws that you loosened earlier, and tighten the screws.



X17 CFS Front

- A. HANDLE
- B. RECOVERY DOME LID
- C. RECOVERY TANK
- D. SOLUTION TANK
- E. SOLUTION TANK FILL PORT
- F. FAUCET FILL HOSE
- G. RECOVERY WINDOW
- H. BRUSH MOTOR BELT COVER
- J. VAC SHOE

Vacuum Connection

- K. VACUUM MOTOR INTAKE COVER
- L. VACUUM CONNECTION TUBE
- M. RECOVERY INLET
- N. RECOVERY TANK HANDLE
- P. VACUUM FLOAT SHUT-OFF
- Q. RECOVERY WINDOW EXTENSION HOSE
- R. VACUUM MOTOR GASKET

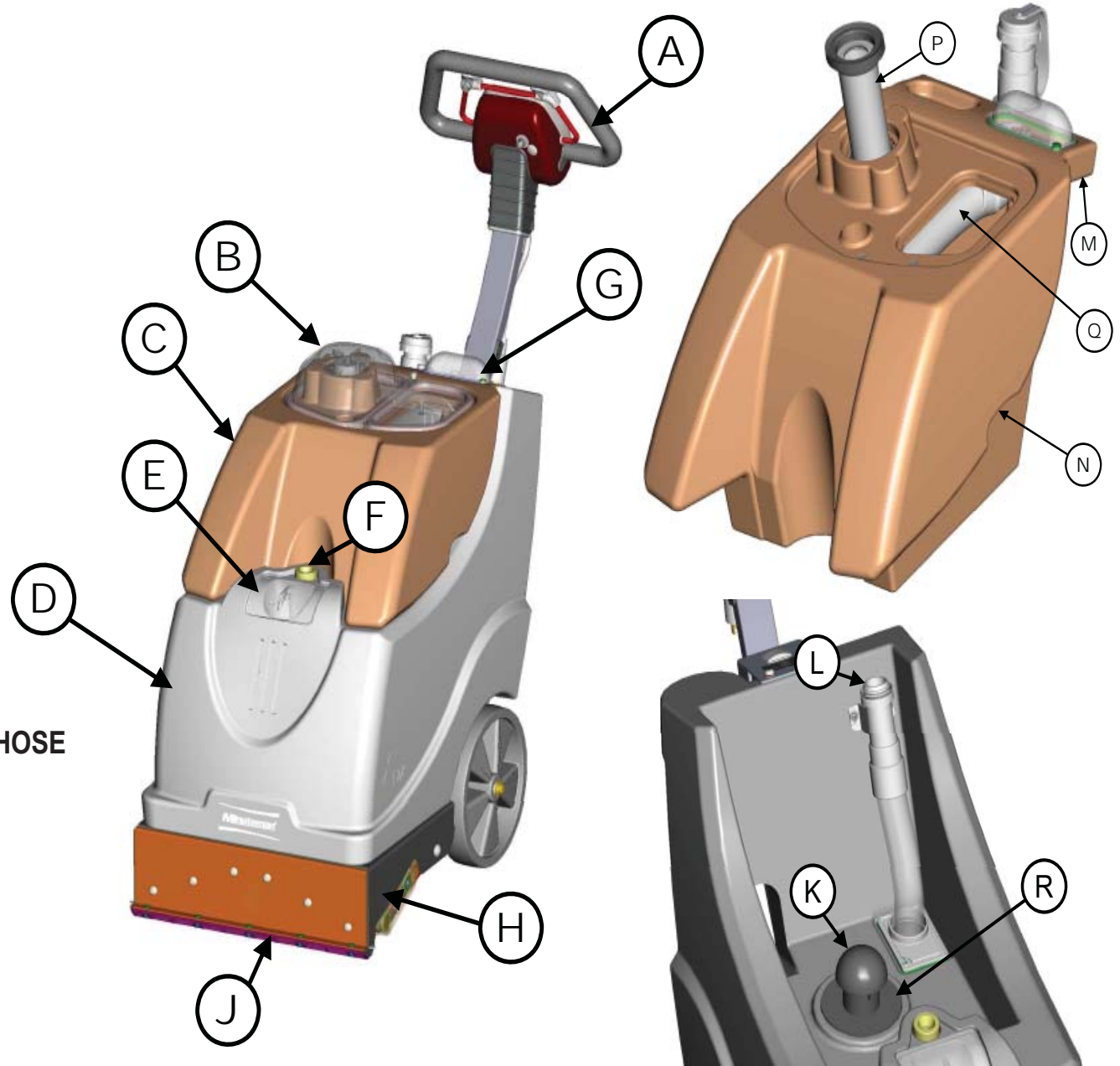

X17 CFS Back & Bottom

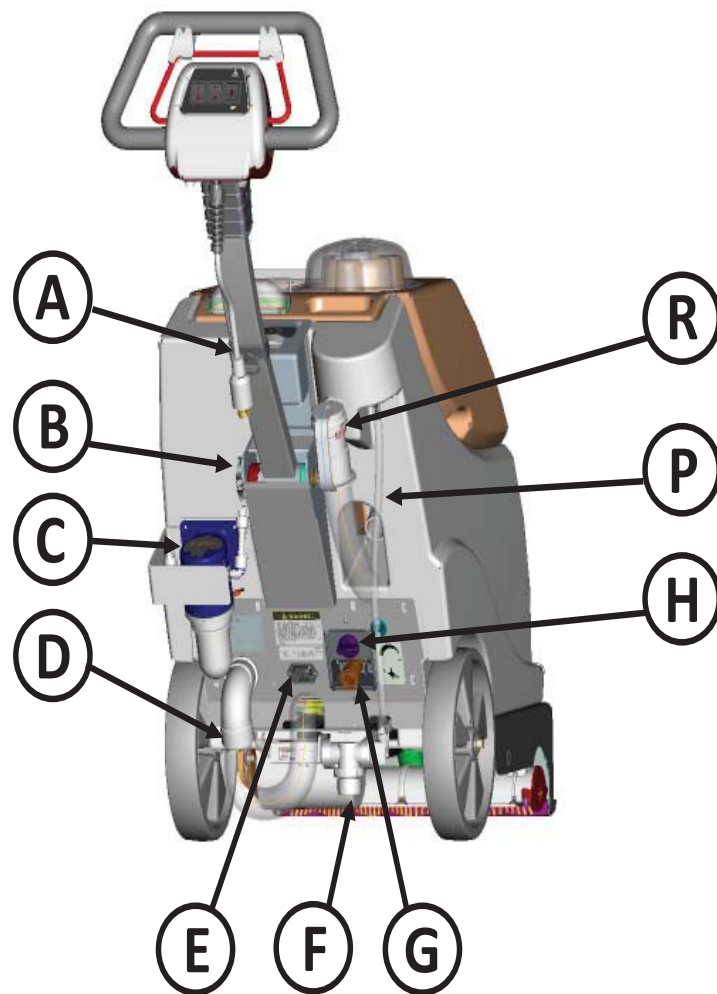

- A. TWIST LOCK POWER CONNECTOR
- B. HANDLE ADJUSTMENT KNOB
- C. CFS CONTROL UNIT
- D. VACUUM HOSE CONNECTION POINT
- E. AUXILIARY POWER OUTLET (FOR MINUTEMAN MOTORIZED TOOL ONLY)
- F. IN-LINE SOLUTION FILTER
- G. OFF AISLE WAND WATER FEMALE QUICK-CONNECT
- H. BRUSH PRESSURE ADJUSTMENT KNOB
- J. VAC SHOE
- K. BRUSH
- L. BRUSH END COVER
- M. SPRAY JETS (2)
- N. BRUSH MOTOR
- P. SOLUTION TANK DRAIN HOSE
- R. RECOVERY TANK DUMP HOSE

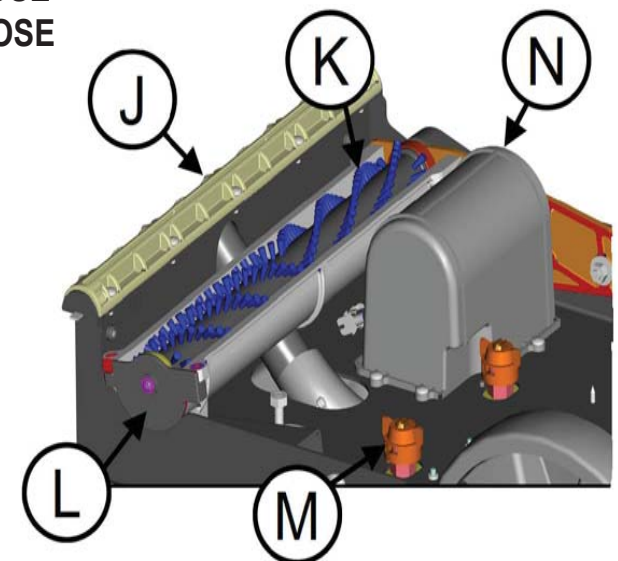

Handle/ Control Panel

- A. **MOMENTARY SPRAY SHUT-OFF**
- B. **BRUSH SWITCH**
- C. **VACUUM SWITCH**
- D. **SPRAY JET \ AUXILIARY SWITCH (OFF AISLE WAND)**

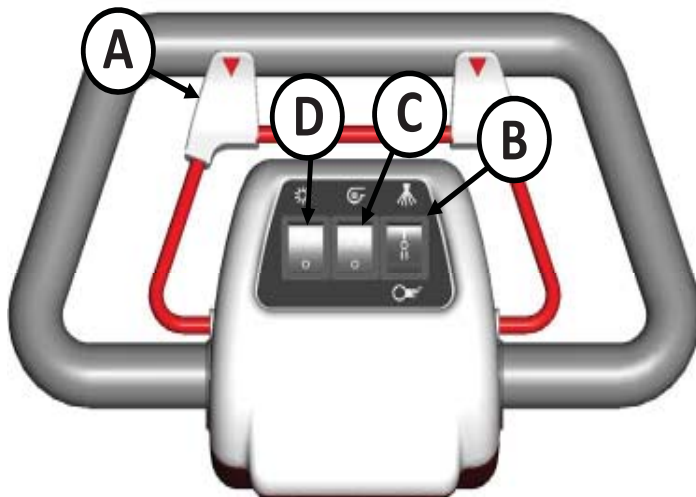

(A) Momentary Handle

When handle is pushed forward the spray jets shut off.

(B) Brush Switch

ON/OFF switch for brush.

Press switch up to **(I)** position to turn ON the brush motor.

Press switch down to **(0)** position to shut OFF brush motor.

Warning: While in Auxiliary Mode, keep the Brush Switch in the off **(0)** position, or damage may occur to carpet.

(C) Vacuum Switch

ON/OFF switch for vacuum.

Press switch up to **(I)** position to turn ON vacuum.

Press switch down to **(0)** position to shut OFF vacuum.

(D) Spray Jet / Auxiliary Switch (Off Aisle Wand)

3-Position switch for spray jet and auxiliary mode function.

(0) position is a neutral OFF position; In the **(0)** position the Spray Jet and Auxiliary Mode are OFF.

Press switch up to **(I)** position to turn ON the spray jets.

Press switch down to **(II)** position to turn ON Auxiliary Mode (Off Aisle Wand - OAW). This will power the auxiliary outlet and turn the water pump on for the auxiliary connection.

See page 20 for OAW connection details.

Warning: When in Auxiliary Mode, confirm Brush Switch is in the OFF position or damage to carpet may occur.

Machine Overview

Circuit Breakers

The circuit breakers are located on bottom and rear of the handle assembly.

1. BRUSH MOTOR BREAKER - **(X17115) 1.5 amp**
(X17230) 1.0 amp
2. VACUUM PUMP BREAKER - **(X17115) 12 amp**
(X17230) 7.5 amp
3. SPRAY JET PUMPAUX POWER & PUMP BREAKER -
(X17115) 1.5 amp
(X17230) 1.0 amp

If any of the functions above are not operating, check if the circuit breaker buttons have tripped. Press to reset.

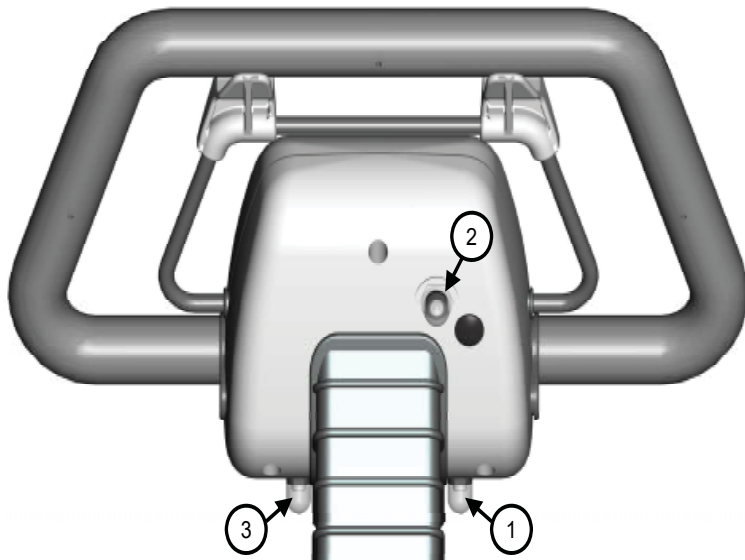

Solution Tank In-line Filter

The **In-line Filter** protects the water pump from large debris. This filter should be cleaned regularly.

Steps to cleaning Solution Tank In-line Filter (See Figure 1):

1. Close the **Shut-off Valve (C)** by turning the handle 90° clockwise. When handle is perpendicular to water line the valve is closed.
2. Next, twist the **Filter Cap (A)** counterclockwise.
3. Remove cap and **Filter (B)**, clean with water.
4. Place filter back into cap, turn cap clockwise onto filter body, tighten by hand. **Note: Using tools to tighten may damage plastic threads.**
5. Open the **Shut-off Valve (C)** by turning the handle 90° counterclockwise.

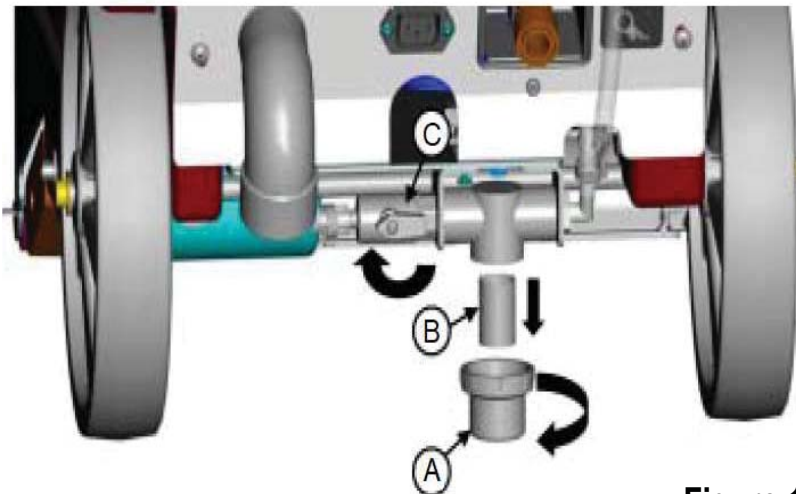

Figure 1

Vacuum Intake Filter

The **Vacuum Intake Filter** protects the intake vacuum from large debris. This filter should be cleaned regularly.

Steps to cleaning Vacuum Intake Filter:

1. Unplug machine from power source outlet.
2. Drain Solution and Recovery tanks.
3. Filter is located above CFS Power Supply Box on the underside of the machine. Tilt machine forward on the vacuum shoe until the filter is visible. (See Figure 2)
4. Once the filter is visible and the machine is supported in a stabilize position - remove the filter. (See Figure 3)
5. Rinse and clean filter with water. Allow filter to air dry.
6. Insert filter back into original location.



Figure 2



Figure 3

Solution Tank Drain Hose

The solution tank may be drained by removing the **Solution Tank Drain Hose (A)** from the **Hose Barb (B)** and routing the hose to a floor drain. (See Figure 4)

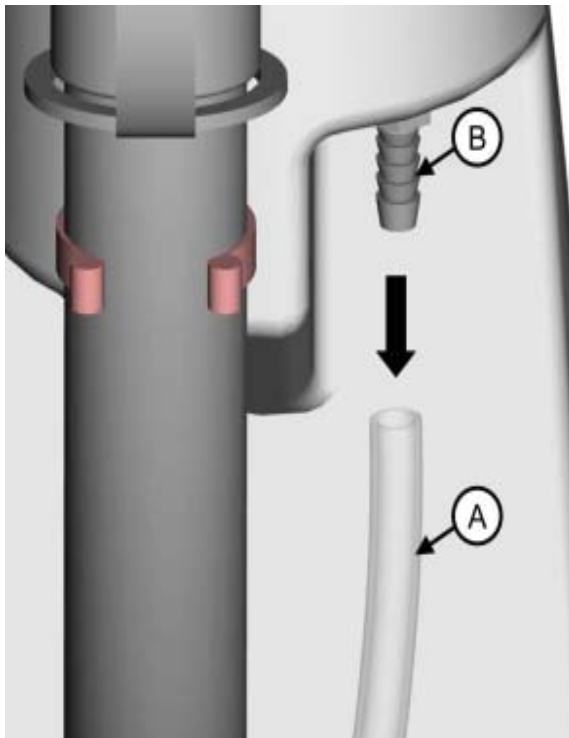

Figure 4

Solution Level Indicator

The solution Tank Drain Hose also serves as a water level indicator for the solution tank. The amount of water remaining in the solution tank can be seen through the clear drain hose. (See Figure 5)

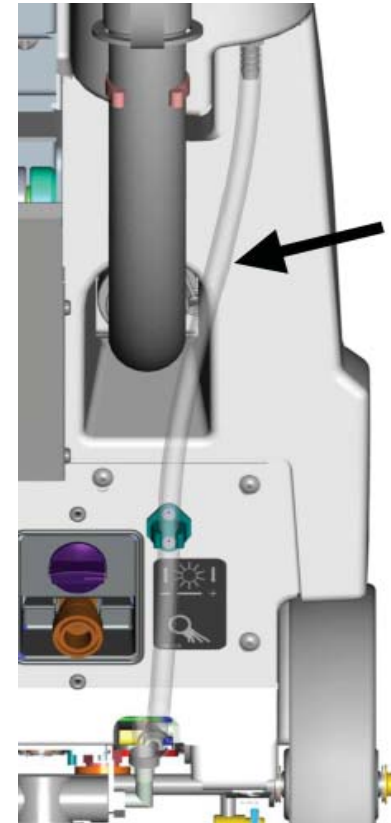

Figure 5

Brush Removal

1. Use a 4mm or 5/32 Hex Tool to remove the flat-head screw on the underside of the right side of the brush housing.
2. Pry open the brush housing door and swing door out. (See Figure 1)
3. Pull brush straight out to the side.

To re-install:

1. Confirm the bristle pattern is in the correct direction.
 - a. When brush is inserted, visually inspect the bristle pattern from underneath the machine, bristle chevron pattern will point to back of the machine. (See Figure 2)
 - b. If bristle chevron pattern is not pointing towards the back of the machine, remove brush and insert opposite brush end in first.
3. To engage the drive hub on the left side with the brush socket, twist the brush until the drive hub lock in place with the brush.
4. Close the brush housing door. The bearing in the door will insert itself into the end of the brush.
5. While holding the housing door closed, re-install flat-head screw from the underside of the housing.

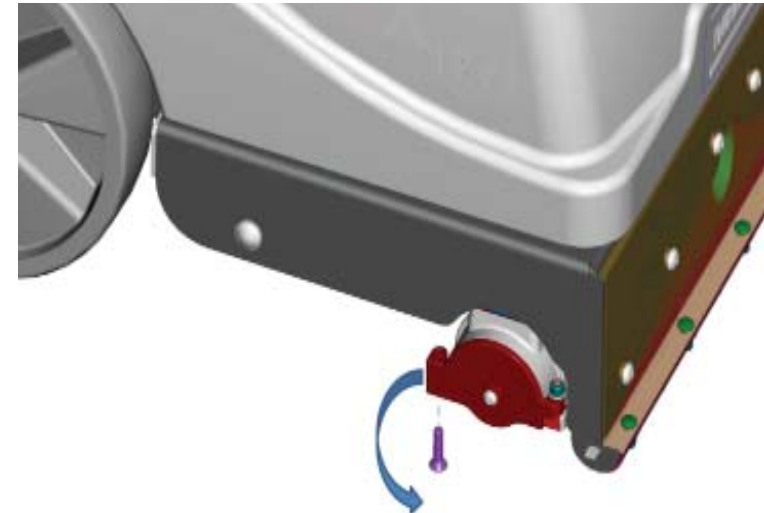

Figure 1

BRUSH – CORRECT BRISTLE PATTERN DIRECTION
VIEW FROM BOTTOM OF THE MACHINE

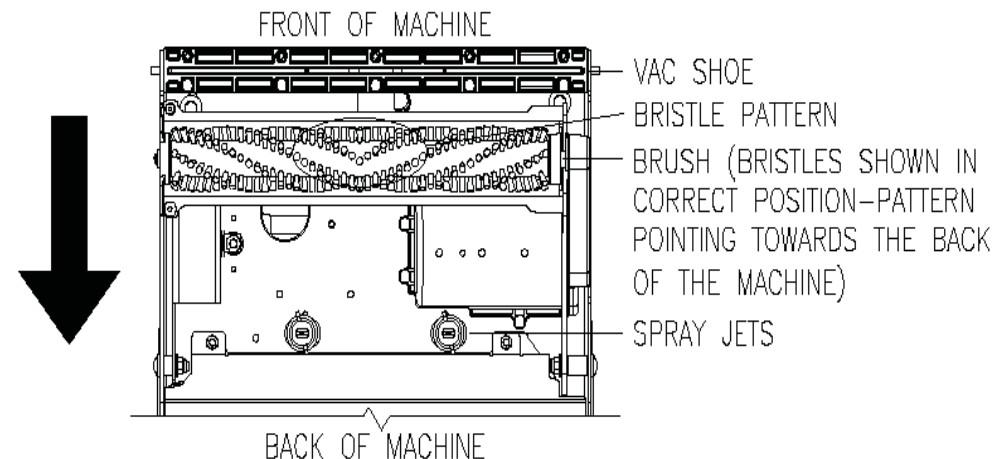

Figure 2

Machine Overview

Brush Pressure Gauge

The brush pressure gauge informs the operator if the brush pressure setting is in optimum range. (See Figure 3) The machine operates best in the green range. If the machine reaches the yellow or red range, the brush pressure can be lowered by using the Brush Pressure Adjustment Knob. See Brush Pressure Adjustment Knob for brush pressure adjustments.



Figure 3

Brush Pressure Adjustment Knob

The Brush Pressure Adjustment Knob allows the operator to decrease or increase the brush pressure. The adjustment knob (item A, Figure 4) is located on the lower right side of the back panel of the machine.

To **DECREASE** brush pressure: Turn the adjustment knob **CLOCKWISE** (in the '-' direction) until the desired pressure range is achieved.

To **INCREASE** brush pressure: Turn the adjustment knob **COUNTER-CLOCKWISE** (in the '+' direction) until the desired pressure range is achieved.



Figure 4

Removable Recovery Tank

To remove tank:

1. Unclip dump hose from solution tank.
2. Pull recovery tank straight up.

To replace tank:

1. Feed dump hose through opening in solution tank
2. Lower tank into place. Recovery vacuum inlet will rest on vacuum connection tube (See pg 10, items L & M)
3. Clip dump hose to solution tank.



High Pressure Spray System (HP)

The X17 CFS machine has a pressure spray system.

The Standard Spray System is a 50psi system that has unique spray nozzles. The combination of the spray pump and the spray nozzles create the 50psi.

50psi Pump: 829757-1

Spray Nozzle: 833145

The High Pressure (HP) Spray System is a 100psi system that has unique spray nozzles. The combination of the HP Spray System and the spray nozzles create the 100psi.

100psi Pump: 829757-1HP

HP Spray Nozzle: 833143

Machine Overview

Handle Adjustment

The X17 handle was designed with operator comfort in mind. The angle position of the handle can be adjusted to suit the needs of the operator.

Angle Adjustment

The handle can be adjusted without tools by loosening the **Handle Adjustment Knob (A)** and rotating the handle to the desired position.

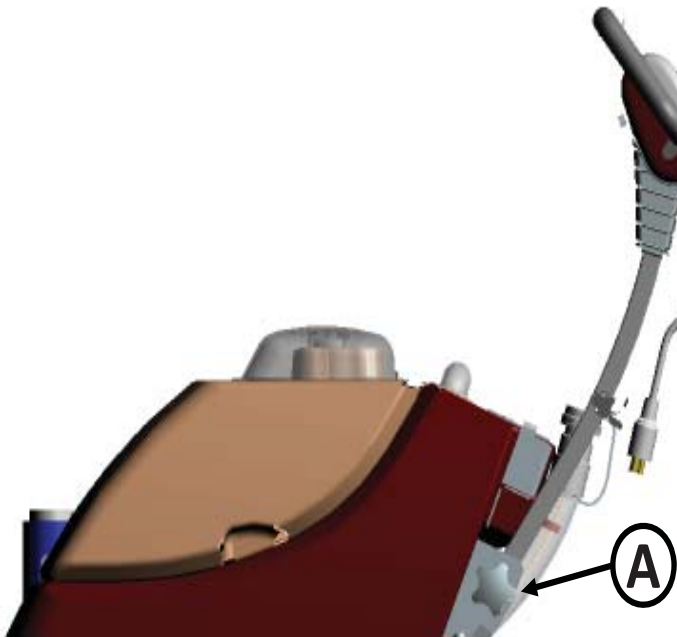

Cord Relief

Use cord relief to prevent cables from disconnecting.

Using the Cord Relief

1. Loop the cord as shown in Figure 1.
2. Lock the cord in place by threading the cable through the relief, then pull the cable down so it locks into place as shown in figure 2.



Figure 1



Figure 2

Accessories

- X17115, use C46300-00 - Motorized Tool
 - X17230, use C46300-02 - Motorized Tool
- Only these tools may plug into the **Auxiliary Power** (Fig. 1/B).



- The Vacuum Hose (Ref. Item G, pg 11) must be first disconnected from the machine back panel. Connect the Suction Hose (Fig. 2/D) tool to the Vacuum Inlet (Fig. 1/A).
- Connect the accessory Power Cord (Fig. 2/E) to the Auxiliary Power (Fig. 1/B).
- A Coupler-Quick Connect (Fig. 2/G) (p/n: 450295) is required to connect the tool Solution Hose (Fig. 2/F) to the quick-connect Solution Coupling (Fig. 1/C).
- To turn ON the tool, the auxiliary switch in the machine handle must be in the (II) position as shown on pg 12, (Item D). The vacuum switch must also be turned on when using the motorized tool.



Figure 1



Caution! Brush motor must be turned OFF when using auxiliary function. If the brush motor is ON, damage to carpet may occur.

- 390070 - Upholstery Tool (Requires Hose Assembly)
- 831255 - Scrub/Vacuum Wand (Requires Hose Assembly)
- 828924 or 830750 - Hose assemblies for non-motorized tools.
Does not require QC coupler (Item G)
- 831019 - Pump-Out Hose
- 17603 - Vac Out Hose

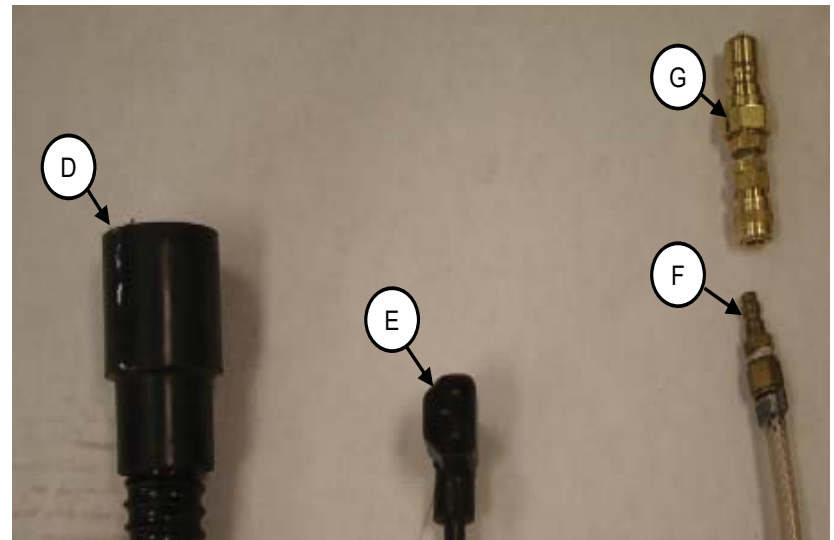

Figure 2

User Maintenance Instructions

All service and repairs should be performed by a qualified service representative or electrician. No user serviceable components are employed in the electrical assembly. No lubrication of the motor is required.

BEFORE CLEANING OR MAINTAINING THE MACHINE, UNPLUG THE ELECTRICAL CORD.

Protect equipment from freezing. Severe pumping system damage can occur if allowed to freeze.

Do not use a power washer to clean in or around the CFS Unit. Pressurized spray could enter the CFS Unit and damage the CFS system electronics.

Daily Maintenance

1. Solution tank should be emptied after each use. Flush solution pump system with 1 gallon of clean, hot water. Operate for 30 seconds through the spray jets, then drain the remaining water with the solution level/drain hose. (Both require flushing for best performance)
2. Removable recovery tank should be rinsed clean and drained using dump hose. Tank does not need to be removed. Wipe off any debris from O-ring under dump hose cap.

3. Dome lid should be cleaned. Pull or rinse off any debris from the attached Filter. Place lid upside-down when storing machine, for ventilation to prevent odor build-up.
4. Vacuum shoe should be cleaned of any debris.
5. Brush should be cleaned of any carpet string or debris.
6. Vac Float Shut-off (pg 10, Item P) should be pulled out, inspected, cleaned if necessary.
7. Solution In-Line Filter (pg 14) should be inspected and cleaned if necessary.
8. Wheels should be cleaned of hard debris which may damage finished hard-surface floors.
9. Electrical Cord should be inspected for any damage.
10. Vacuum Hose should be inspected for tight fit at the rear of the machine, and to the bottom of the Vac Connection Tube.

Bi-Monthly/Monthly/Yearly Maintenance

Every Two Weeks:

1. Purge solution system to remove residue build-up by flushing as follows:
 - a. Use - 1 quart White Vinegar to two gallons clean hot water - in the solution tank, operate solution pump with spray jets installed for two full minutes.
 - b. Drain the remaining solution with the solution level/drain hose (this is important to help keep the hose clear).
 - c. Use 2 gallons clean hot water (no vinegar) in the solution tank, operate solution pump with spray jets installed for two full minutes. Drain the remaining water with the solution level/drain hose.
 - d. It is Important to repeat the 2 gallon rinse (step C) as vinegar may affect coloring in carpet.
 - e. Repeat procedure if machine has not been flushed daily.
2. Remove Brush (pg 16), clean any debris off brush hubs at both ends.
3. Wipe off any debris from bottom side of chassis.
4. Rinse off the Dome Lid Filter.

Monthly:

1. Check Spray Jets for full width spray pattern. Remove (twist orange cap ¼ turn counter-clockwise) and clean with soft-bristle brush if necessary. Do not use pins or wire, which can damage the spray tip.
2. Clean the Recovery Window (pg 10, item G) by removing (2 screws) and wiping out with a soft cloth, use hot water and white vinegar or gentle detergent. Take care not to damage the gasket. Inspect gasket for cracks/damage.
3. Flush out Recovery Window Extension Hose (pg 10, item Q) while Recovery Window is removed by pouring water/vinegar solution through the hose. Rinse with clear water.
4. Clean off any debris from the Vac Connection Tube & Recovery Inlet (pg 10, items L & M).
5. Clean & Inspect Vacuum Motor Gasket (pg 10, item R) for damage, and ensure Vac Motor Cover (pg 10, item K) is in place.
6. Inspect Brush Motor Belt for wear (pg 10, item H). Replace if necessary.

Yearly:

1. Have a qualified service technician check the vacuum motor carbon motor brushes once a year or after every 500 operating hours.

Cord Storage

The X17 CFS is supplied with a detachable cord for ease of storage.

- Regularly inspect cord for signs of damage. If cord is damaged replace immediately.
- Do not use with damaged cord or plug. If appliance is not working as it should, has been dropped, damaged, left outdoors, or dropped into water, return to service center.
- Do not pull or carry by cord, use cord as handle, close a door on cord, or pull cord around sharp edges or corners.
- Do not run appliance over cord. Keep cord away from heated surfaces.
- Do not unplug by pulling cord. To unplug, grasp the plug, not the cord.
- Do not handle plug or appliance with wet hands.
- This equipment should be stored indoors and not exposed to rain.

Review Safety Instructions & Decal Warning

For the operator's safety:

- Review and become familiar with all the Safety Instructions described in this manual.
- Visually inspect the Warning Decal, #715061 shown below, for damage and make sure it is legible. This decal is located on the lower back machine wall, directly below the base of the handle. If this decal is damaged or worn, please replace as necessary.

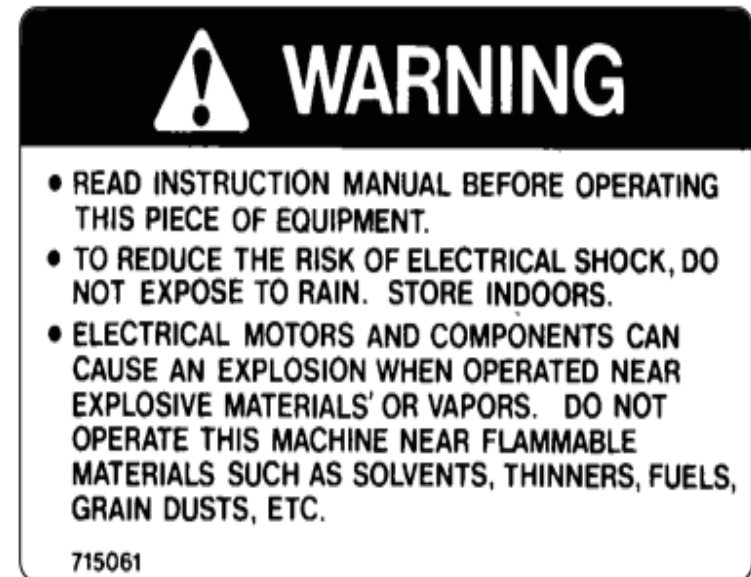

Decal 715061

Operating Instructions

Filling the X17 CFS

1. Remove clear solution cover lid from front of machine, or use the supplied faucet fill hose (B), by pulling hose out and holding rubber inlet against faucet.
2. Fill solution tank with desired amount of warm water.
 - MAX water temperature is 120°F / 50°C (Ref. C). See Decal 17262197 below.
 - DO NOT add Chemicals or Detergents; WATER ONLY when filling the X17 CFS solution tank (Ref. A). See Decal 715474 below. Adding chemicals or detergents will prematurely reduce the life of the CFS system.



Decal 715474



Decal 17262197

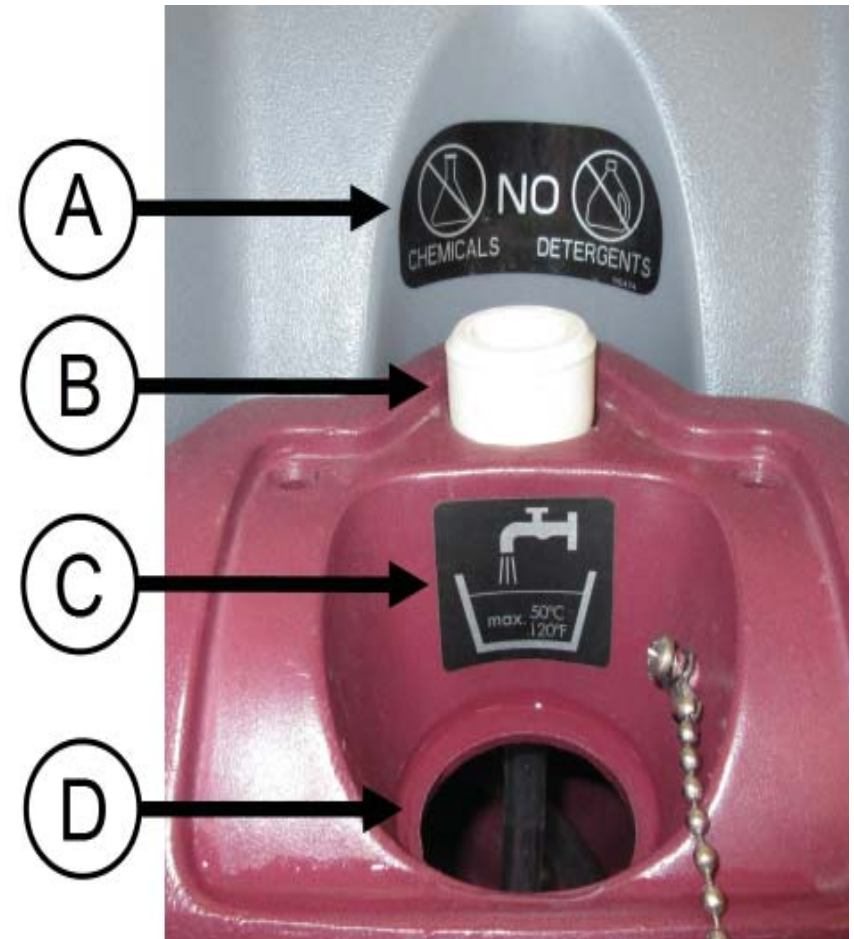

Figure 1

Operating Instructions

Preparing the Carpet for Cleaning:

Carpet should be thoroughly vacuumed and obstacles relocated before beginning the cleaning cycle. Heavy traffic lane areas should be pre-treated or spotted with Minuteman Pre-Treat order #902183 for best results.

To Begin Cleaning:

1. Always work away from the cord.
2. Machine operates by pulling backwards over carpet.
3. The recovery dome lid (pg 10, item B) should be properly seated on Recovery Tank (item C) for proper vacuum recovery.
4. Control Panel Switch Identifications:
Normal Cleaning Mode
 1. Turn on vacuum switch (Fig 1/C).
 2. Turn on brush switch (Fig 1/B).
 3. Turn on the solution pump (Fig 1/D) to position 'I'.
 4. Adjust brush pressure at rear of machine, until brush pressure gauge reads in green zone.
 5. Solution pump should be turned off by either using the momentary bail (Fig 1/A), or flip the switch (Fig 1/D) spray jet to the center position 'O'; 6" before the end of each cleaning pass.

During the cleaning cycle, care should be taken not to allow foam to build up in the recovery tank. If this should happen, the machine should be turned off. Defoamer order #910543

should be added to the recovery tank only, never into the solution tank. Foam should not be seen inside the right side of the dome lid.

Confirm that the CFS unit is working correctly by observing the power indicator light. The recovery water level can be viewed from the operator's position of the machine through the left side of the visible recovery dome. The X17 CFS has a float ball shut off located in the recovery tank that cuts off suction to the vacuum hose. When the recovery tank is full, the vacuum motor will become noticeably louder and the machine will not pick up water. Recovery tank must be emptied. (NOTE : Never tilt machine completely back with recovery tank in place. Always remove tank and set to the side before tilting complete machine.) To empty the recovery tank use the recovery tank dump hose (pg 11, item D). Unclip the hose from the tank and turn the cap a quarter turn counter-clockwise and dump waste water into a floor drain or utility sink.

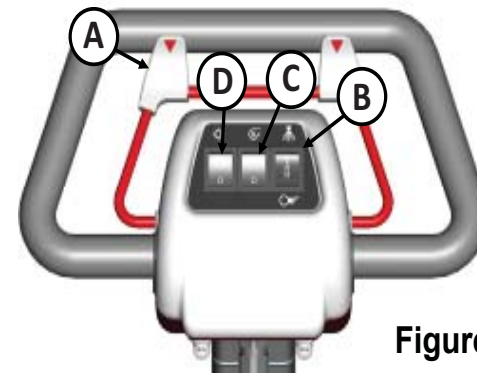

Figure 1

Cartridge Replacement

1. Turn power to the machine off.
2. Very Important: Turn off water flow to the device.
3. To remove the cartridge, hold the head steady, and then twist the replaceable cartridge and pull down. (See Fig. 10)
4. To install the new cartridge, hold the head steady, and then push the cartridge up into the head and twist to seat. (See Fig. 11)
 - a. The alignment marks on the head and cartridge should align when correctly installed. (See Fig. 12)
5. Restore power to the machine, and resume use.



Fig. 10



Fig. 11



Fig 12

Chemical Free Solution Unit

Troubleshooting CFS Unit

LED Color & State	Status	How to Fix
Green (solid)	Power ON.	N / A - Device is operating properly.
Yellow (flashing)	Cartridge has reached end of life.	Replace the cartridge as soon as possible.
Red (solid)	Cartridge has expired.	Replace the cartridge now.
Yellow (solid) + Red (flashing)	Service is required.	Cycle power and replace cartridge. If error persists, contact manufacturer for support. Device is not generating ozone.
Yellow (flashing) + Red (solid)	Cartridge has stopped functioning or is installed incorrectly.	Replace cartridge. If cartridge has just been replaced, remove and reinstall to ensure correct installation. Then, cycle power. If error persists, contact manufacturer for support.
Yellow (flashing) + Red (flashing)	Ozone time-out. Water leak.	Fix leak and cycle power. Device shuts off.

Troubleshooting Guide

Caution! Unplug power cord before servicing machine component.

Problem	Possible Cause	Remedy
Machine does not function	Power cord may be disconnected at the twist lock or wall outlet.	Check connections and reconnect if necessary.
	Wall outlet breaker may have tripped.	Reset breaker.
No water dispensed from spray jets	Circuit breaker in handle tripped.	Reset breaker.
	Solution tank in-line filter valve may be closed.	Open valve.
	Sprayjet Switch is in OFF (O) or AUX (II) position.	Flip sprayjet switch to ON (I) position.
	No water in solution tank.	Fill solution tank.
Spray intermittent or streaked	Solution hoses may be clogged or kinked.	Check hose for clogs, remove any debris if found. Replace kinked hose if found.
	Solution tank in-line filter valve may be clogged.	Clean strainer thoroughly.
	The spray jets may be clogged.	Remove the spray tips and clean as required. Do not clean out the hole in the jet with a pin or wire. This may cause permanent damage.

Troubleshooting

Brush does not turn ON	Circuit breaker in handle tripped.	Reset breaker.
	Belt is damaged.	Replace belt.
	Debris is lodged in the brush housing.	Remove debris.
	Switch is in OFF (O) position.	Flip switch to ON (I) position.
Solution recovery is reduced	Dome lid filter of vac float shut off may be clogged.	Rinse out items.
	Recovery dome lid is not seated properly.	Reposition dome lid.
	Recovery tank is not seated properly over intake tube.	Reposition recovery tank so the intake tube is inserted into the inlet.
	Recovery tank dump hose may not be closed properly.	Disconnect cap from drain hose then reconnect, to ensure the cap and hose snap together.
	Bad seals on recovery dome lid.	Check the gasket on the lid for damage. Replace if needed.
	Vac shoe may be clogged.	Check vac shoe for debris and remove if necessary.
	Vac shoe may be worn.	Replace vac shoe.
Vacuum motor does not start.	Circuit breaker in handle may have tripped.	Reset breaker.
	Motor carbon brush may be worn.	Contact a qualified service technician.
	Switch is in OFF (O) position.	Flip switch to ON (I) position.



Minuteman International Made Simple Commercial Limited Warranty REVISION P EFFECTIVE 5/1/201

Minuteman International, Inc. warrants to the original purchaser/user that the product is free from defects in workmanship and materials under normal use. Minuteman will, at its option, repair or replace without charge, parts that fail under normal use and service when operated and maintained in accordance with the applicable operation and instruction manuals. All warranty claims must be submitted through and approved by factory authorized repair stations.

This warranty does not apply to normal wear, or to items whose life is dependent on their use and care, such as belts, cords, switches, hoses, rubber parts, brushes, electrical motor components or adjustments. Parts manufactured by Minuteman are covered by and subject to the warranties and/or guarantees of their manufacturers. Please contact Minuteman for procedures in warranty claims against these manufacturers.

Special warning to purchaser -- Use of replacement filters and/or pre-filters not manufactured by Minuteman or its designated licensees, will void all warranties expressed or implied. A potential health hazard exists without original equipment replacement.

All warranted items become the sole property of Minuteman or its original manufacturer, whichever the case may be.

Minuteman disclaims any implied warranty, including the warranty of merchantability and the warranty of fitness for a particular purpose. Minuteman assumes no responsibility for any special, incidental or consequential damages.

This limited warranty is applicable only in the U.S.A. and Canada, and is extended only to the original user/purchaser of this product. Customers outside the U.S.A. and Canada should contact their local distributor for export warranty policies. Minuteman is not responsible for costs or repairs performed by persons other than those specifically authorized by Minuteman. This warranty does not apply to damage from transportation, alterations by unauthorized persons, misuse or abuse of the equipment, use of non-compatible chemicals, or damage to property, or loss of income due to malfunctions of the product.

If a difficulty develops with this machine, you should contact the dealer from whom it was purchased.

This warranty gives you specific legal rights, and you may have other rights which vary from state to state. Some states do not allow the exclusion or limitation of special, incidental or consequential damages, or limitations on how long an implied warranty lasts, so the above exclusions and limitations may not apply to you.

Model	Parts	Labor	Poly	Travel**
Cord Electric Group	5yrs	3yrs	12yrs	90 days
Battery Auto Scrubbers (incl. on board charger)	5yrs	3yrs	12yrs	90 days
Battery and Manual Sweepers	3yrs	3yrs	12yrs	90 days

Exceptions.....

Model	Parts	Labor	Poly	Travel**
Port A Scrub, all models (incl. on board charger)	1yr	6months	12yrs	90 days
A3S Blower	1yr	1yr	0	0
Phenom Dual Motor Upright Vacuums	2yrs	2yrs	0	0
Explosion Proof Vacuum	1yr	1yr	0	0
Propane Burnisher	1yr	1yr	0	90 days
E14BQP and E14115 scrubber	1yr	1yr	12yrs	90 days
**Travel, 2 hours max				

<i>Stand-alone Battery Chargers:</i>	One year
<i>Replacement Parts:</i>	Ninety days
<i>Batteries:</i>	0-3 months full replacement, 4-12 months pro-rate
<i>Polypropylene Plastic Tanks:</i>	12yr warranty, no additional labor

Minuteman[®]



Excellence Meets Clean

Minuteman International, Inc. · 14N845 U.S. Route 20 · Pingree Grove, Illinois 60140 USA

Phone 800-323-9420

www.minutemanintl.com

A Member of the Hako Group

988725UMCFS

Rev C 03/18